

TLM-CSTM

Four Post Fully Customisable Lift



- » Custom built to your requirements
- » Multiple stopping points
- » Hydraulic driven with strong cylinder & chains
- » Superior safety with double-chain lifting system
- » Option to stand on ground, or have pit-installed
- » Power pack can be relocated
- » Optional remote control
- » Lifting capacity: 2000-6000kg
- » Lifting height: 2000-13000mm
- » Platform length: 2000-7000mm
- » Platform width: 2000-5000mm
- » Emergency stop button
- » Pressure relief valve
- » 24V electric control system
- » Power overload protection
- » Limit switch
- » Pneumatic cylinders
- » Mechanical anti-falling locks
- » 5 Years Structural, 1 Year electrical, parts & labour warranty

INCLUSIONS



Hydraulic Oil

TLM-CSTM With Pit

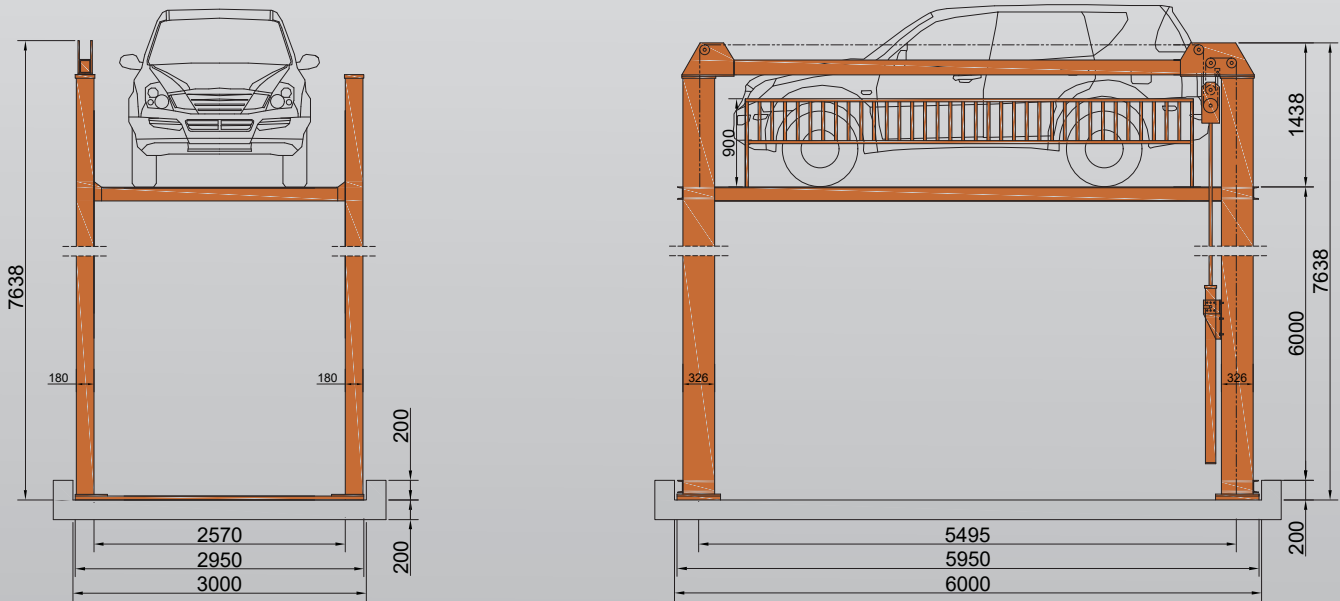

**** Example only - Dimensions are customisable ****

TLM-CSTM With Ramp

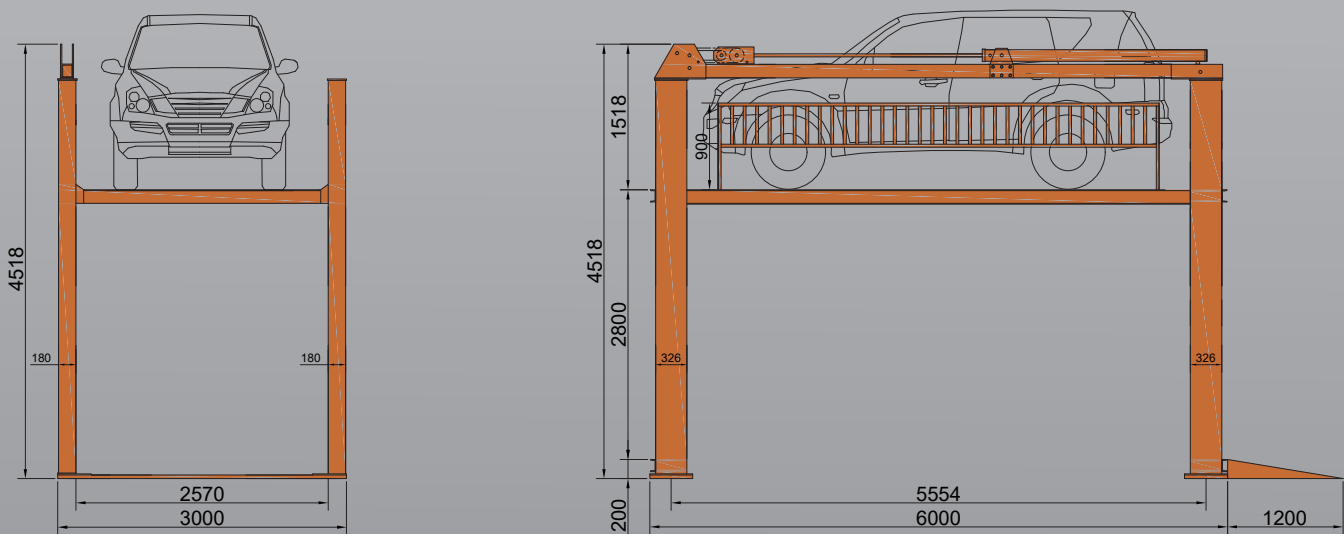

**** Example only - Dimensions are customisable ****