

# TLV4.0WH-L

## 4.0 Ton 4 Post Workshop Hoist - Extra Long



- » 4.0 Ton lifting capacity
- » Durable charcoal Hammertone powder coat finish
- » Mechanical single point lock release
- » Mechanically locks multiple intervals
- » 5 Year structural & 1 year electrical, parts & labour warranty
- » Worksafe design registration

### INCLUSIONS



Hydraulic Oil

### OPTIONS



RJ45  
Rolling Air  
Pump Jack



EAE  
Turntable Set

Wheel  
Alignment Kit

# TLV4.0WH-L

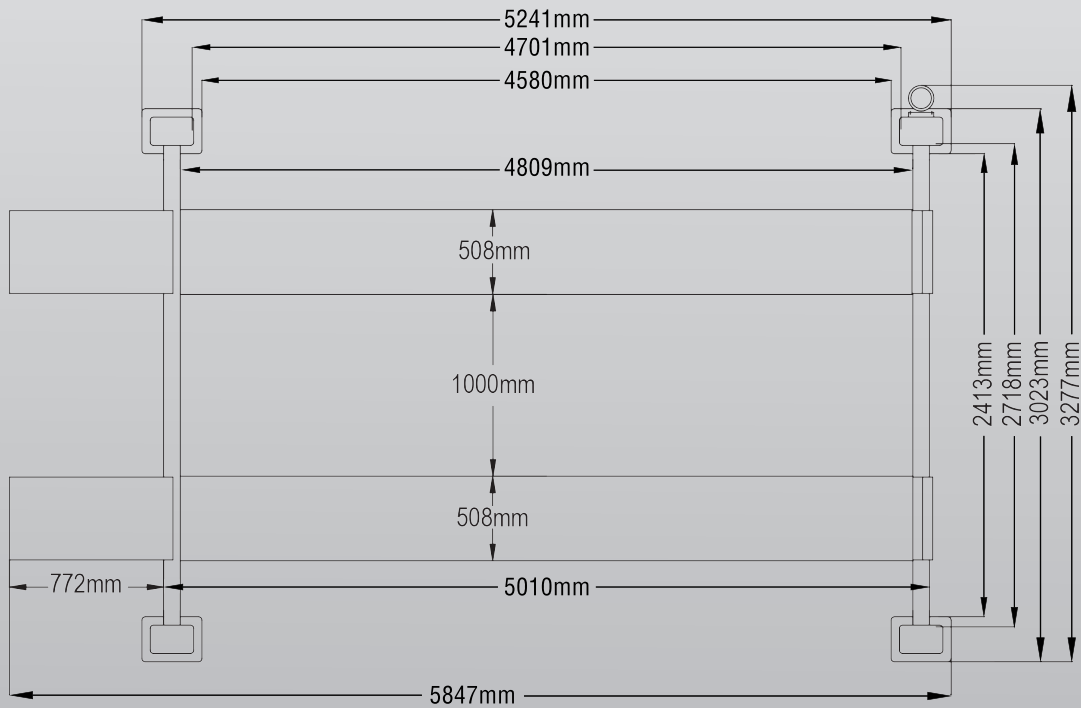

<b>Minimum Concrete Requirement</b>
100mm
<b>Recommended Ceiling Height</b>
3.6m

<b>Power Requirements</b>
<b>240v</b>
2.2kw 14.5 amps
<b>3 phase</b>
2.2kw 7 amps
No neutral required

<b>Freight Dimensions</b>
495 x 60 x 110cm
1085kg

